

Replacement for the American Air Filter Series 16 (models ENR, ENH, WY & YY)

Islandaire EZ Series 16 is a replacement for the American Air Filter models of ENR, ENH, WY and YY units. Our commercial duty construction with heavy gauge galvanized steel and superior components create an efficient, reliable unit. This design eliminates the need for any interior or exterior renovation. Use of the existing wall sleeve-cabinet and louver saves time and money, two very important factors in today's competitive environment! If the need does occur where the wall sleeve-cabinet and/or louver needs to be replaced, we manufacture these accessories as well.



FEATURES

- Proudly Assembled in the U.S.A.
- Dual Condensate Drains
- ETL listed product
- Superior Energy Efficiency Ratios (EERs)
- Commercial Duty Construction with Heavy Gauge Galvanized Steel, extensive rust prevention features
- Designed for exact replacement of existing sleeve opening
- High EER (Energy Efficient) Rotary Compressors
- High Efficiency BLDC Evaporator and Condenser Motors
- High-Efficiency Refrigeration Coils Used to Provide Superior Heat Transfer
- Hydrophilic Coated Evaporator Coils
- Units Available as Cooling only, Cooling with Electric Heat, Cooling with Hydronic Heat, or Heat Pumps
- Custom Options Available
- Available with wired and wireless wall thermostats
- NYC MEA Number 358-93-E Vol. II

Voltage/Line Cord	
1 - 115v, 20 Amps	5 - 115v, 15 Amps
2 - 208/230v, 20 Amps	6 - 115v, Hard Wire
3 - 208/230v, 30 Amps	7 - 277v, 20 Amps
4 - 208/230v, Hard Wire	8 - 277v, Hard Wire
	9 - 208/230v, 15 Amps

Cooling Capacity
07 - 7,500 BTU
09 - 9,500 BTU
12 - 12,000 BTU
15 - 15,000 BTU

System Type
K - Std. Chassis R32
L - Heat Pump R32

Component
EZ - Cooling Chassis

Model Type
16 - eAmer. Air Filter 16

Functional Options

- A - None
- B - Motorized Fresh Air Damper
- C - Fan Cycle Switch
- D - Indoor Freeze Protect
- E - Winter Operation

Functional Option Codes*

A - A	Q - BE
B - B	T - C
C - BC	U - CD
D - BCD	V - CDE
E - BCDE	Y - CE
H - BCE	2 - D
L - BD	3 - DE
M - BDE	6 - E

*Codes are entered into model number.

Return/Discharge Options

- 1 - Bot. Ret./Top Dis.
- 3 - Bot. Ret./Ducted Top Dis.
- 4 - Front Ret./Top Dis.
- 6 - Front Ret./Ducted Top Dis.

Identity Code

- 0 - Special
- 5 - Standard

EZ 12 L 2 16 A 1 A 1 5 A A

Heating Options

- A - None Cooling Only
- B - 2.5 kW Elec. Heat (208v - 277v)
- C - 3.4 kW Elec. Heat (208v - 277v)
- D - 4.2 kW Elec. Heat (208v - 277v)
- E - 5.0 kW Elec. Heat (208v - 277v)
- F - Hyd. Fan Cycle W/T-Stat (115v - 277v)
- G - Hyd. With Aquastat (115v - 277v)
- H - Hyd. W/2.5 kW B.U. Heat (208v - 277v)
- I - Hyd. W/3.4 kW Dual Stage (208v - 277v)
- Y - 1.3 kW Elec. Heat (115v Only)

Hydronic Options

- 1 - None
- 2 - 24v NC Valve
- 3 - 115v NC Valve
- 4 - 230v NC Valve
- 5 - 277v NC Valve
- 6 - 24v NO Valve
- 7 - 115v NO Valve
- 8 - 230v NO Valve
- 9 - 277v NO Valve
- A - Line Volt NO/NC Switch
- B - 24v NO/NC Switch

Room Controls

- E - Wireless Thermostat (specify type when ordering)
- F - Wall Thermostat Interface, Master
- G - Wall Thermostat Interface, Slave
- K - None
- N - Wall Thermostat Interface, Std. Elect. Cntrls
- S - Std. Electronic Controls (Unit Mounted)

Power Mgt. Options

- A - None
- B - Power Disconnect
- C - Energy Mgt. N/O
- D - Energy Mgt. N/C
- E - Emerg. Power 115v
- F - Emerg. Power 230v
- G - Emerg. Power 277v

Power Mgt. Codes*

A - A	N - BG
B - B	P - C
C - BC	Q - CE
D - BCD	R - CF
E - BCF	S - CG
F - BCG	T - D
G - BD	U - DE
H - BDE	V - DF
J - BDF	W - DG
K - BDG	X - E
L - BE	Y - F
M - BF	Z - G

*Codes are entered into model number.

*Specifications are subject to change due to ongoing product development.

6140551 Rev. 11/14/25

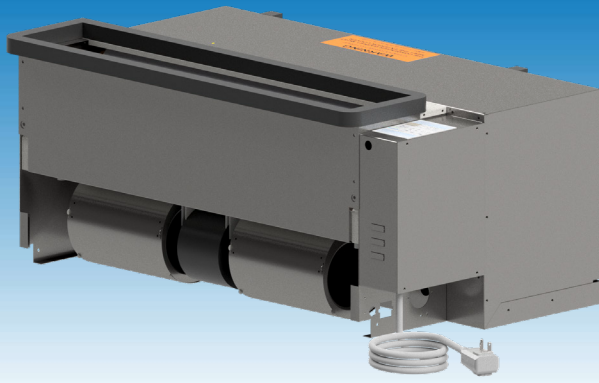

MODELS

	EZ07			EZ09			EZ12			EZ15	
VOLTS	115	208 / 230	277	115	208 / 230	277	115	208 / 230	277	208 / 230	277
BTUH COOL	7,000	7,000	7,000	9,200	9,600	9,400	11,800	11,800	11,500	14,500	14,500
AMPS COOL	6.39	3.53 / 3.20	2.65	8.87	4.90 / 4.43	3.77	12.22	6.44 / 5.83	4.89	8.73 / 7.89	6.62
WATTS COOL	735	735	735	1,020	1,020	1,045	1,405	1,340	1,355	1,815	1,835
EER	9.5	9.5	9.5	9.0	9.4	9.0	8.4	8.8	8.5	8.0	7.9
HIGH COOL CFM (m³/min)	375 (10.6)	375 (10.6)	375 (10.6)	400 (11.3)	400 (11.3)	400 (11.3)	425 (12.0)	425 (12.0)	425 (12.0)	450 (12.7)	450 (12.7)
LOW COOL/HEAT CFM (m³/min)	320(9.0)	320 (9.1)	320 (9.0)	350 (9.9)	350 (9.9)	350 (9.9)	350 (9.9)	350 (9.9)	350 (9.9)	400 (11.3)	400 (11.3)
BTUH HEATING	6,800	6,800	6,800	9,000	9,400	9,200	11,000	11,000	11,500	13,500	13,500
WATTS HEATING	710	710	710	975	985	1,000	1,240	1,110	1,250	1,520	1,520
C.O.P.	2.8	2.8	2.8	2.7	2.8	2.7	2.6	2.9	2.7	2.6	2.6

Heating Option	Voltage ⁽¹⁾	Wattage	BTU/h	Amps ⁽²⁾
B	208	2,045	7,000	9.83
	230	2,500	8,500	10.87
	277	2,500	8,500	9.03
C	208	2,780	9,500	13.37
	230	3,400	11,600	14.78
	277	3,400	11,600	12.27
D	208	3,435	11,700	16.51
	230	4,200	14,300	18.26
	277	4,200	14,300	15.16
E	208	4,090	14,000	19.66
	230	5,000	17,100	21.74
	277	5,000	17,100	18.05
H	208	2,045	7,000	9.83
	230	2,500	8,500	10.87
	277	2,500	8,500	9.03
I	208	2,780	9,500	13.37
	230	3,400	11,600	14.78
	277	3,400	11,600	12.27
Y	115	1,300	4,400	11.30

Where applicable, cooling capacities are specified at conditions of 95 °F DB/75 °F WB (35 °C DB/24 °C WB) outdoor and 80 °F DB/67 °F WB (27 °C DB/19 °C WB) indoor and heating capacities are specified at conditions of 47 °F DB/43 °F WB (8 °C DB/6 °C WB) outdoor and 70 °F DB/60 °F WB (21 °C DB/16 °C WB) indoor in accordance with AHRI 310/380 and CSA C744 standards. Wattage, Amperage, EER, and COP listings include compressor, evaporator motor and condenser fan motor. The above ratings are a typical heat pump style unit.

* CFM values are dry coil (not in cooling mode).

- (1) Voltage is Single Phase, Alternating Current and R.M.S.
- (2) Amp values are for heater element only.

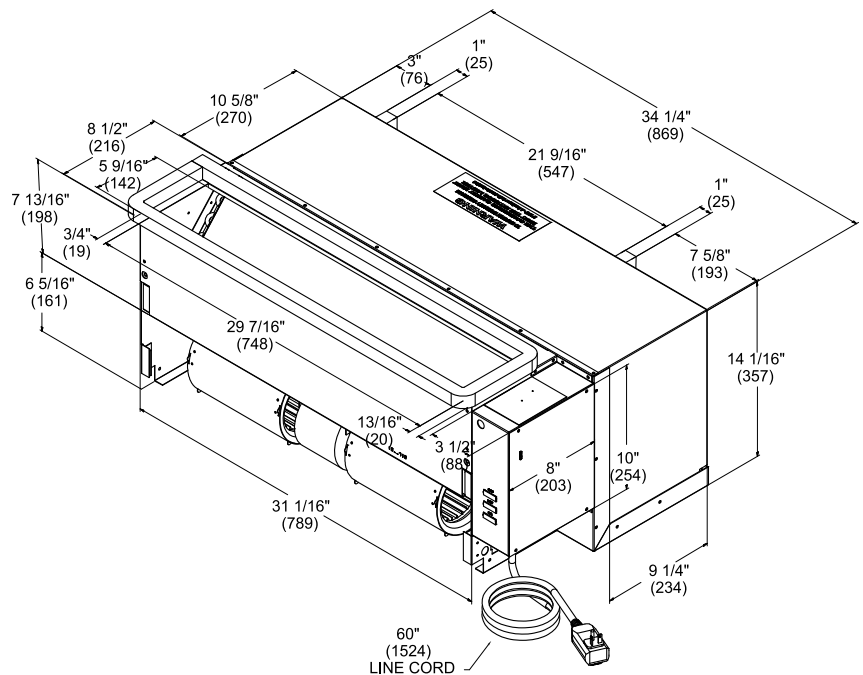

Line Voltage	Maximum Amperage	Wall Socket Configuration	Receptacle Number	Electrical Heat Options
115	12		NEMA 5-15R	1.3
115	16		NEMA 5-20R	1.7
208/230	12		NEMA 6-15R	2.5
208/230	16		NEMA 6-20R	3.6
208/230	24		NEMA 6-30R	4.2 - 5.0
277	16		NEMA 7-20R	2.5 - 4.2
277	24		NEMA 7-30R	5.0

EZ SERIES 16

Unit Accessories

WALL SLEEVE/CABINETS

PART NUMBER	DESCRIPTION	APPROX. WT.	DIMENSIONS		
			DEPTH	WIDTH	HEIGHT
2400124-00	EZ16 Sleeve-Cabinet, w/o Louver, Long, Hydronic Heat	50 lbs.	20.875"	41.50"	16.00"
4080247-00	EZ16 Sleeve-Cabinet, w/ Louver, Short, Electric Heat	50 lbs.	20.375"	37.50"	16.00"
4080348-00	EZ16 Sleeve-Cabinet, w/o Louver, Short, Electric Heat	50 lbs.	20.375"	37.50"	16.00"
4080484-00	EZ16 Front Panel, Short	12 lbs.	1.50"	35.125"	16.00"
4080517-00	EZ16 Front Panel, Long	12 lbs.	1.50"	39.125"	16.00"

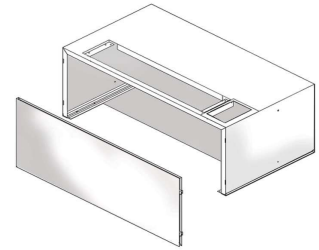

HYDRONIC COILS

PART NUMBER	DESCRIPTION	APPROX. WT.	DIMENSIONS		
			DEPTH	WIDTH	HEIGHT
6030135	EZ16 Hydronic Coil without Vent	15 lbs.	32.625"	6.00"	1.062"
6030148	EZ16 Hydronic Coil with Vent	15 lbs.	33.442"	6.00"	0.750"

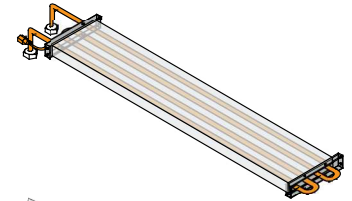

LOUVERS

PART NUMBER	DESCRIPTION	APPROX. WT.	DIMENSIONS		
			DEPTH	WIDTH	HEIGHT
6070043	EZ16 Exterior Architectural Louver, Long	8 lbs.	1.063"	41.00"	15.50"
6070066	EZ16 Exterior Architectural Louver, Short	8 lbs.	1.125"	37.132"	15.50"

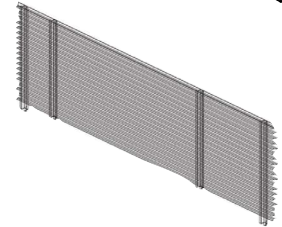

THERMOSTATS

PART NUMBER	DESCRIPTION	APPROX. WT.	FEATURES		
			CONNECTION	STAGE	DISPLAY
6041206	Islandaire Non-Programmable, 2 Fan Speed	1.0 lbs.	Wireless	Single	Horizontal
6041210	Islandaire Programmable, 2 Fan Speed	1.0 lbs.	Wireless	Single	Horizontal
6041228	Islandaire Programmable (7 Day/5-1-1 Day/ Non-Programmable), Two Fan Speed	1.0 lbs.	Wired	Single	Horizontal
6041373	Islandaire Wireless, WiFi Programmable	1.0 lbs.	Wireless	Single	Horizontal



FILTERS

PART NUMBER	DESCRIPTION	APPROX. WT.	DIMENSIONS		
			DEPTH	WIDTH	HEIGHT
6080015	EZ16 Filter, Standard	2 lbs.	.250"	30.750"	7.000"
6080024	EZ16 Filter, Custom	2 lbs.	.250"	34.625"	7.375"



SUBBASES

PART NUMBER	DESCRIPTION	APPROX. WT.	DIMENSIONS		
			DEPTH	WIDTH	HEIGHT
4080776	EZ16 Subbase Assembly, Long (hydronic heat)	2 lbs.	5.25"	41.50"	7.25"
4082589	EZ16 Subbase Assembly, Short (electric heat)	2 lbs.	5.25"	37.00"	5.10"

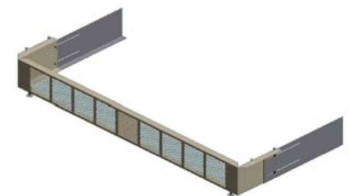

OTHER OPTIONS

PART NUMBER	DESCRIPTION	APPROX. WT.	FEATURES
4090007	Drain Kit	2 lbs.	

**Ask your salesman about
our DR. PTAC option!***



*100% conditioned
fresh air

**EZ Series VH Unit
Available**

Vertical Water Source Hybrid Heat
Pump, Replacement For:

CGC InnKeeper/HomeKeeper

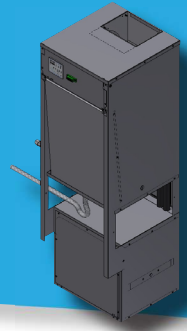

Scan for more information

500 Middle Country Road, St. James, NY 11780 • 1-800-886-2759
e-mail: sales@islandaire.com • www.islandaire.com
Ph: 631-471-2900 • Fax: 631-471-2913



Locally Represented By:

