

## Replacement for the Singer and McQuay EA, ES and RS Series

Islandaire EZED Series is a replacement for the Singer and McQuay models of EA, ES and RS units. Our commercial duty construction with heavy gauge galvanized steel and superior components create an efficient reliable unit. This design eliminates the need for any interior or exterior renovation. Use of the existing wall sleeve-cabinet and louver saves time and money, two very important factors in today's competitive environment! If the need does occur where the wall sleeve-cabinet front panel and/or louver needs to be replaced, we manufacture these accessories as well.

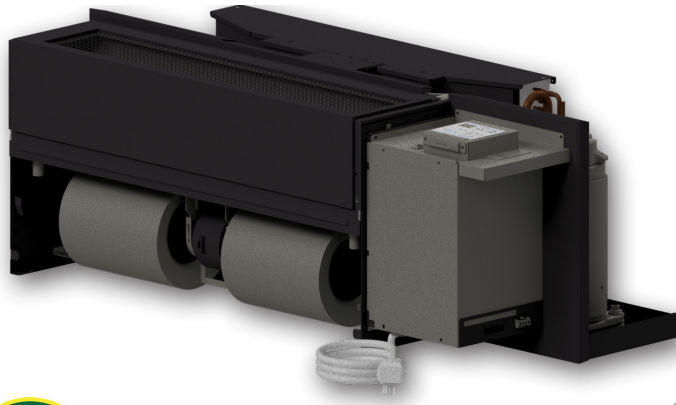

### FEATURES:

- Proudly Designed and Engineered in the U.S.A.
- Whisper Quiet Tangential Wheel
- Superior Energy Efficiency Ratios (EERs) and Coefficient of Performances (COPs)
- Commercial Duty Construction with Heavy Gauge Galvanized Steel
- Energy Efficient Rotary Compressors
- Fan Cycle Option Standard
- Indoor Freeze Protection Standard
- Hi Pressure Cutout Standard
- Units Available as Cooling only, Cooling with Electric Heat, Cooling with Hydronic Heat, Cooling with Heat Pump
- Custom Options Available
- Available with wired and wireless wall thermostats
- Includes New Painted Front Panels and Blank Off Plate
- ETL listed products
- Designed for exact replacement of existing sleeve opening



**System Type**  
K - Std. Chassis R32  
L - Heat Pump R32

**Voltage/Line Cord**  
2 - 208/230v, 20 Amps  
3 - 208/230v, 30 Amps  
4 - 208/230v, Hard Wire  
7 - 277v, 20 Amps  
8 - 277v, Hard Wire  
9 - 208/230v, 15 Amps  
F - 277v, 30 Amps

**Model Type**  
ED - Singer, McQuay

**Cooling Capacity**  
09 - 9,500 BTU  
12 - 12,000 BTU  
16 - 15,000 BTU

**Component**  
EZ - Cooling Chassis

**Return/Discharge Options**  
1 - Bot. Ret./Top Dis.  
3 - Bot. Ret./Ducted Top Dis.  
4 - Front Ret./Top Dis.  
6 - Front Ret./Ducted Top Dis.

**Functional Options**  
A - None  
B - Motorized Damper

**Functional Option Codes**  
A - A  
B - B

\*Codes are entered into model number.

**Identity Code**  
0 - Special  
5 - Standard

**EZ ED 09 K 2 A 1 S 4 5 A A**

**Heating Options**  
3 - Dual Stage 3.4 kW Elec (2.5 kW / 0.9 kW)  
4 - Dual Stage 5.0 kW Elec (3 kW / 2 kW)  
A - None Cooling Only  
B - 2.5 kW Elec. Heat (208v - 277v)  
C - 3.4 kW Elec. Heat (208v - 277v)  
D - 4.2 kW Elec. Heat (208v - 277v)  
E - 5.0 kW Elec. Heat (208v - 277v)  
F - Hyd. Fan Cycle W/T-Stat (115v - 277v)  
G - Hyd. With Aquastat (115v - 277v)  
H - Hyd. W/2.5 kW B.U. Heat (208v - 277v)  
I - Hyd. W/3.4 kW Dual Stage (208v - 277v)  
J - Hyd. W/4.2 kW B.U. Heat (208v - 277v)

**Hydronic Options**  
1 - None  
2 - 24v NC Valve  
4 - 230v NC Valve  
5 - 277v NC Valve  
6 - 24v NO Valve  
8 - 230v NO Valve  
9 - 277v NO Valve  
A - Line Volt NO/NC Switch  
B - 24v NO/NC Switch

**Room Controls**  
E - Wireless Thermostat (specify type when ordering)  
F - Wall Thermostat Interface, Master  
G - Wall Thermostat Interface, Slave  
N - Wall Thermostat Interface, Std. Elect. Cntrls  
S - Std. Electronic Controls (Unit Mounted)  
W - Unit Mounted T-Stat (specify type when ordering)

**Power Mgt. Options**  
A - None  
B - Power Disconnect  
C - Energy Mgt. N/O  
D - Energy Mgt. N/C  
E - Emerg. Power 115v  
F - Emerg. Power 230v  
G - Emerg. Power 277v

**Power Mgt. Codes\***  
A - A N - BG  
B - B P - C  
C - BC Q - CE  
D - BCD R - CF  
E - BCF S - CG  
F - BCG T - D  
G - BD U - DE  
H - BDE V - DF  
J - BDF W - DG  
K - BDG X - E  
L - BE Y - F  
M - BF Z - G

\*Codes are entered into model number.

\*Specifications are subject to change due to ongoing product development.

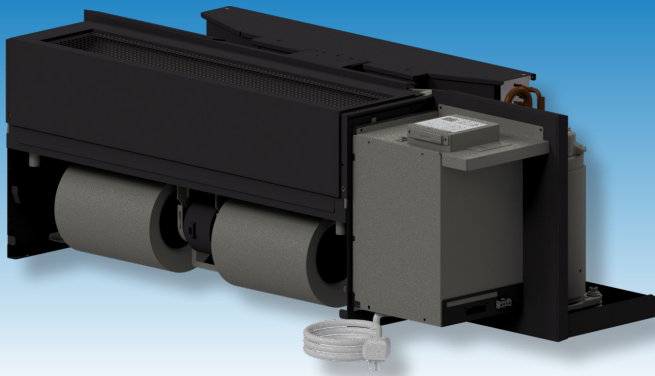

	EZ09		EZ12			EZ16		
<b>VOLTS</b>	230	208	230	208	277	230	208	277
<b>BTUH COOL</b>	8,800	8,700	11,700	11,600	11,600	14,700	14,600	14,700
<b>AMPS COOL</b>	3.40	3.70	4.90	5.30	4.30	7.10	7.70	5.80
<b>WATTS COOL</b>	750	735	1,075	1,045	1,115	1,530	1,505	1,485
<b>EER</b>	12.1	12.2	10.9	11.1	10.4	9.6	9.7	10.3
<b>CFM HIGH COOL</b>	330	330	380	380	380	430	430	400
<b>CFM LOW COOL/HEAT</b>	260	240	260	240	260	260	240	260
<b>BTUH HEATING</b>	7,900	7,800	10,500	10,300	10,700	13,400	13,200	13,200
<b>WATTS HEATING</b>	680	655	970	990	980	1,310	1,250	1,250
<b>C.O.P.</b>	3.4	3.5	3.2	3.2	3.2	3.0	3.1	3.1
<b>NOISE INDOOR/OUTDOOR (DBA)</b>	45/69	45/69	45/69	45/69	45/69	45/69	45/69	45/69
<b>REFRIG. TYPE</b>	R32	R32	R32	R32	R32	R32	R32	R32
<b>SHIPPING WT. (LB)</b>	101	101	111	111	107	112	112	112

Heating Option	Voltage (1)	Wattage	BTU/h	Amps (2)
3	208	2,780	9,500	13.37
	230	3,400	11,600	14.78
	277	3,400	11,600	12.27
4	208	4,090	14,000	19.66
	230	5,000	17,100	21.74
	277	5,000	17,100	18.05
B & H	208	2,045	7,000	9.83
	230	2,500	8,500	10.87
	277	2,500	8,500	9.03
C & I	208	2,780	9,500	13.37
	230	3,400	11,600	14.78
	277	3,400	11,600	12.27
D	208	3,435	11,700	16.51
	230	4,200	14,300	18.26
	277	4,200	14,300	15.16
E	208	4,090	14,000	19.66
	230	5,000	17,100	21.74
	277	5,000	17,100	18.05
K	208	4,090	14,000	19.66
	230	5,000	17,100	21.74
	277	7,250	24,800	26.18
L	208	5,890	20,100	28.31
	230	7,200	24,600	31.30
	277	7,200	24,600	25.99

(1) Voltage is Single Phase, Alternating Current and R.M.S.

(2) Amp values are for heater element only.

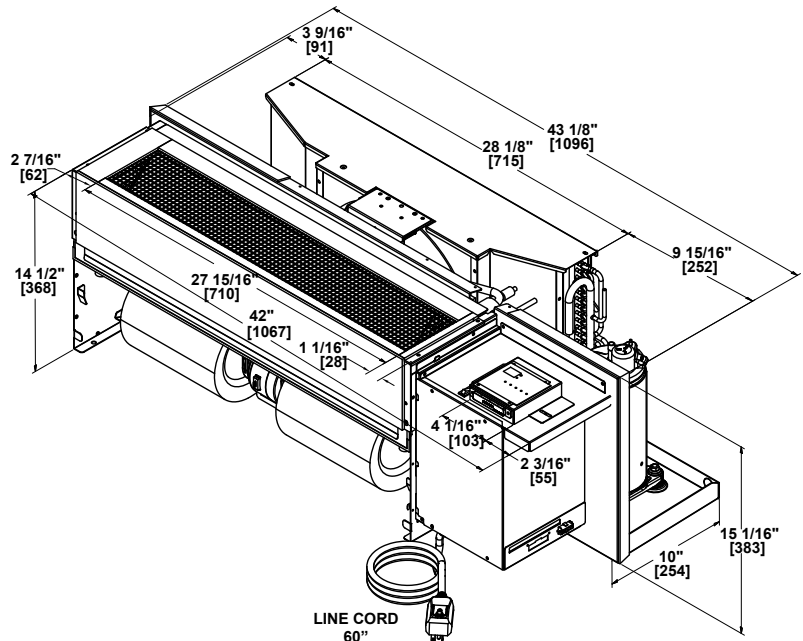

Line Voltage	Maximum Amperage	Wall Socket Configuration	Receptacle Number	Electrical Heat Options
208/230	12		NEMA 6-15R	2.5
208/230	16		NEMA 6-20R	3.6
208/230	24		NEMA 6-30R	4.2 - 5.0
277	16		NEMA 7-20R	2.5 - 4.2
277	24		NEMA 7-30R	5.0

### ENCLOSURE

PART NUMBER	DESCRIPTION	APPROX. WT.	DIMENSIONS		
			DEPTH	WIDTH	HEIGHT
Consult Factory	EZED Enclosure Assembly (various styles/sizes available)	-	-	-	-



### WALL SLEEVES/PANELS

PART NUMBER	DESCRIPTION	APPROX. WT.	DIMENSIONS		
			DEPTH	WIDTH	HEIGHT
2400354-XX	EZED Wall Sleeve Assembly, w/o Front Panel (XX = paint code suffix)	45 lbs.	20.750"	44.750"	16.438"
4083479-XX	EZED Front Panel, Type EA, ES and RS (XX = paint code suffix)	7 lbs.	0.750"	43.760"	15.280"

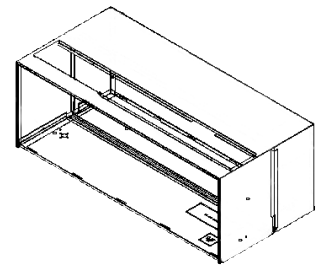

### LOUVERS

PART NUMBER	DESCRIPTION	APPROX. WT.	DIMENSIONS		
			DEPTH	WIDTH	HEIGHT
6070079	EZED Exterior Architectural Louver, Standard	2 lbs.	1.125"	44.750"	15.281"

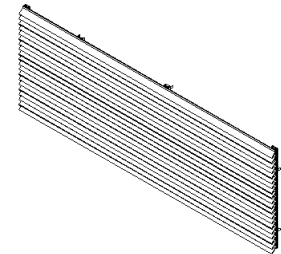

### HYDRONIC COILS

PART NUMBER	DESCRIPTION	APPROX. WT.	DIMENSIONS		
			DEPTH	WIDTH	HEIGHT
6030445	Hydronic Coil Assembly, Right-Piped	10 lbs.	2.375"	34.183"	5.675"
6030446	Hydronic Coil Assembly, Left-Piped	10 lbs.	2.375"	34.183"	5.675"

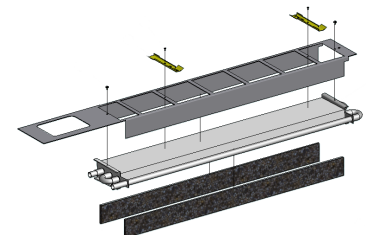

### THERMOSTATS

PART NUMBER	DESCRIPTION	APPROX WT.	FEATURES		
			CONNECTION	STAGE	DISPLAY
6041206	Islandaire Non-Programmable, 2 Fan Speed	1.0 lbs.	Wireless	Single	Horizontal
6041210	Islandaire Programmable , 2 Fan Speed	1.0 lbs.	Wireless	Single	Horizontal
6041228	Islandaire Programmable (7 Day/5-1-1 Day/ Non-Programmable), Two Fan Speed	1.0 lbs.	Wired	Single	Horizontal
6041373	Islandaire Wireless, WiFi Programmable	1.0 lbs.	Wireless	Single	Horizontal
6041374	Islandaire Wireless, WiFi (Receiver Only)	1.0 lbs.	N/A	N/A	N/A
6041375	Wet Switch Kit for 6041373 Thermostat	1.0 lbs.	N/A	N/A	N/A



### FILTERS

PART NUMBER	DESCRIPTION	APPROX WT.	DIMENSIONS		
			DEPTH	WIDTH	HEIGHT
6080000	EZED Filter, Aluminum, Front Return	2 lbs.	0.250"	30.75"	8.50"
6080036	EZED Filter, Aluminum, Bottom Return	2 lbs.	0.469"	41.625"	5.25"

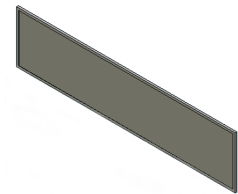

### LINE CORD/HARDWIRE KITS

PART NUMBER	DESCRIPTION	APPROX WT.	DIMENSIONS		
			DEPTH	WIDTH	HEIGHT
4092552	EZED Hardwire Kit, 48", 115/277V	2 lbs.	N/A	N/A	N/A
4092539	EZED Hardwire Kit, 48", 208/230V	2 lbs.	N/A	N/A	N/A
6160146	Line Cord, 277V, 15 Amp (6 Foot)	2 lbs.	-	-	-
6160032	Line Cord, 277V, 20 Amp (6 Foot)	2 lbs.	-	-	-
6160676	Line Cord, 277V, 30 Amp (6 Foot)	2 lbs.	-	-	-



**Ask your salesman about  
our DR. PTAC option!\***



\*100% conditioned  
fresh air

## **EZ Series VH Unit Available**

*Vertical Water Source Hybrid Heat  
Pump, Replacement For:*

**CGC InnKeeper/HomeKeeper**

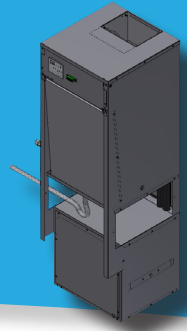

Scan for more information

500 Middle Country Road, St. James, NY 11780 • 1-800-886-2759  
e-mail: [sales@islandaire.com](mailto:sales@islandaire.com) • [www.islandaire.com](http://www.islandaire.com)  
Ph: 631-471-2900 • Fax: 631-471-2913



Locally Represented By: