

# EZ SERIES CY

## Replacement for the Chrysler PTAC

Islandaire EZ Series CY is a direct replacement for the Chrysler PTAC units. Our commercial duty construction with heavy gauge galvanized steel and superior components create an efficient reliable unit. This design eliminates the need for any interior or exterior renovation. Use of the existing wall sleeve-cabinet and louver saves time and money, two very important factors in today's competitive environment! Reciprocating compressor only. Ducted units must be remote thermostat.

### FEATURES

- Proudly Made in the U.S.A.
- ETL listed products
- Superior Energy Efficiency Ratios (EERs)
- Commercial Duty Construction with Heavy Gauge Galvanized Steel
- Designed for exact replacement of existing sleeve opening
- Energy Efficient Rotary Compressors
- P.S.C. Evaporator and Condenser Motors
- High-Efficiency Refrigeration Coils Used to Provide Superior Heat Transfer
- Units Available as Cooling only, Cooling with Electric Heat.

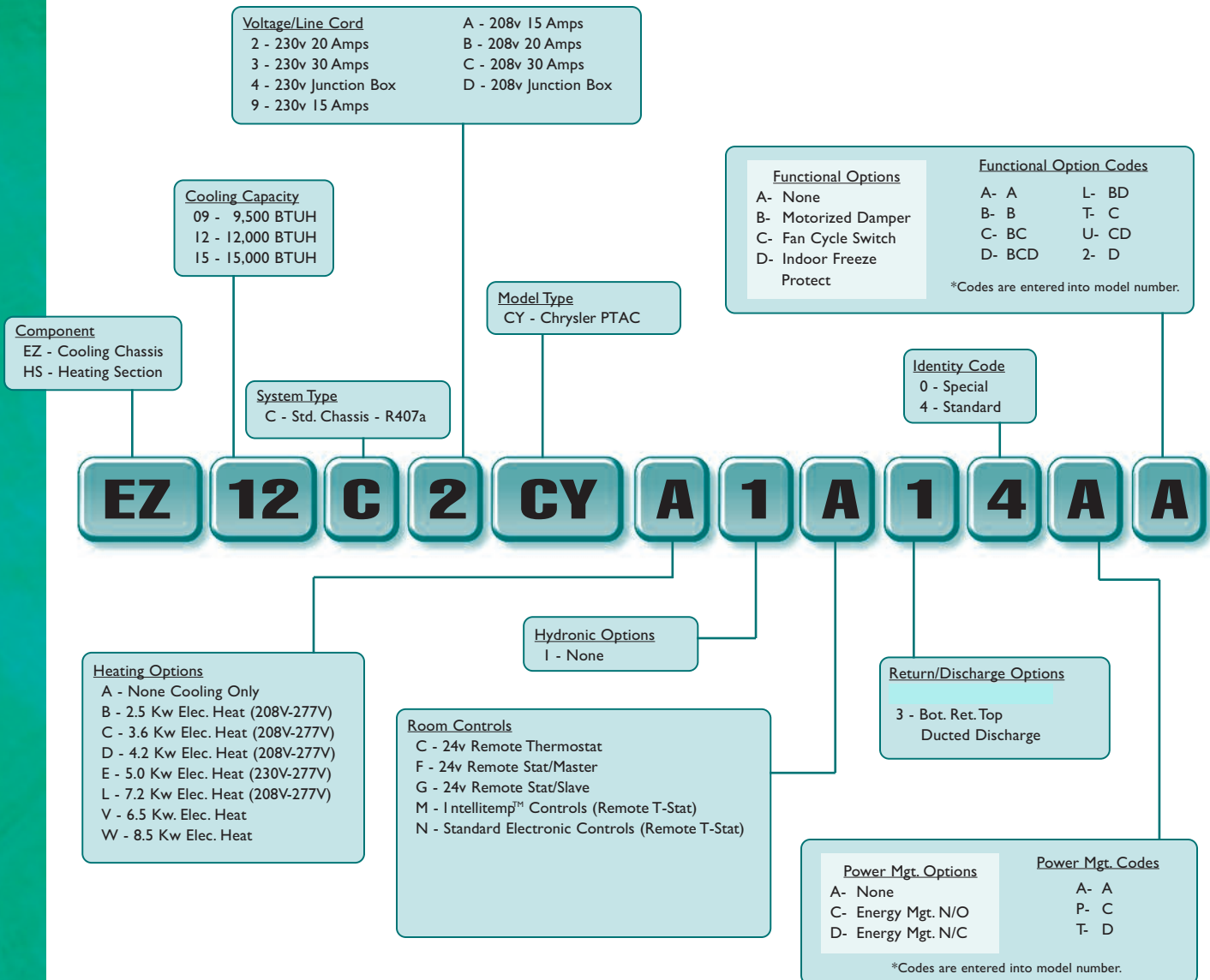

\*Specifications are subject to change due to ongoing product development.

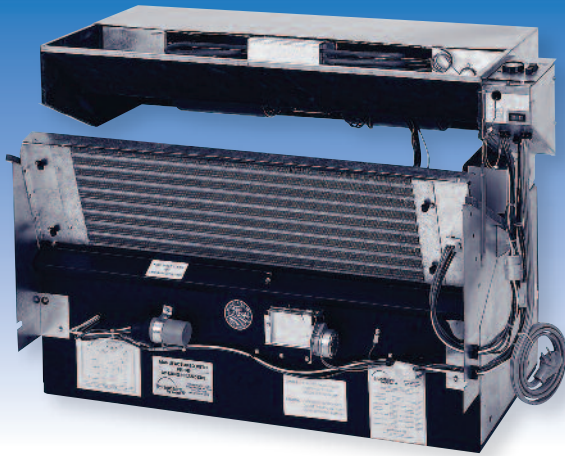

### ACCESSORIES:

Please consult your sales representative.

### MODELS

	EZ07				EZ09				EZ12				EZ15		
	115	230	208	277	115	230	208	277	115	230	208	277	230	208	277
<b>BTUH COOLING</b>	7,000	7,000	6,800	7,000	9,500	9,500	9,300	9,500	12,200	12,200	12,000	12,200	15,000	14,800	15,000
<b>AMPS</b>	6.76	3.30	3.70	2.81	8.76	4.38	4.85	3.64	11.66	5.83	6.45	4.84	7.99	8.9	6.63
<b>WATTS COOLING</b>	731	723	723	731	945	986	986	945	1,247	1,328	1,328	1,247	1,768	1,768	1,671
<b>EER</b>	9.58	9.68	9.41	9.58	10.05	9.63	9.43	10.05	9.78	9.19	9.04	9.78	8.48	8.37	8.98
<b>CFM HIGH</b>	340	340	320	340	400	400	380	400	400	400	380	400	460	440	460
<b>CFM LOW</b>	260	260	240	260	260	260	240	260	340	340	320	340	340	320	340
<b>BTUH HEATING</b>	7,100	7,100	6,900	7,100	9,300	9,300	9,100	9,300	11,400	11,400	11,200	11,400	14,300	14,200	14,800
<b>WATTS HEATING</b>	751	749	749	751	884	864	864	884	1,281	1,258	1,258	1,281	1,646	1,646	1,715
<b>C.O.P.</b>	2.77	2.78	2.70	2.77	3.09	3.16	3.09	3.09	2.61	2.66	2.61	2.61	2.55	2.53	2.53

Heating Option	Voltage (1)	Wattage	B.T.U.s (2)	Amps (3)
B	208	2,050	7,000	10.46
	230	2,500	8,535	11.47
	277	2,500	8,535	9.63
C	208	2,950	10,070	14.78
	230	3,600	12,290	16.25
	277	3,600	12,290	13.60
D	208	3,433	11,720	17.10
	230	4,200	14,330	18.86
	277	4,200	14,330	15.76
E	208	4,100	14,000	20.31
	230	5,000	17,070	22.34
	277	5,000	17,070	18.65
L	208	5,900	20,100	29.8
	230	7,200	24,550	32.8
	277	7,200	24,550	27.4
V	208	4,910	16,762	24.30
	230	6,000	20,484	26.50
	277	6,000	20,484	22.10
W	208	6,550	22,362	31.90
	230	8,000	27,312	35.2
	277	8,000	27,312	29.3

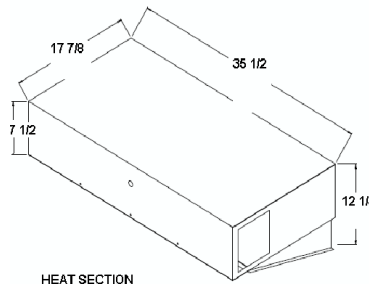

HEAT SECTION

(1) Voltage is Single Phase, Alternating Current and R.M.S. (2) Heating Capacity (B.T.U./Hr.) based on indoor blower motor and heating elements. (3) Amp values are a combination of indoor blower motor and heating elements.

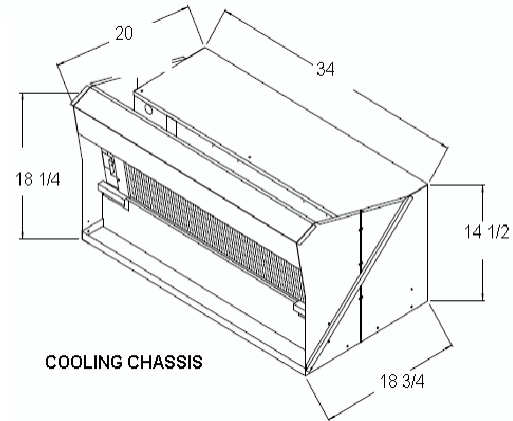

COOLING CHASSIS

Line Voltage	Maximum Amperage	Wall Socket Configuration	Receptacle Number	Electrical Heat Options
115	16		NEMA 5-20R	N/A
208/230	12		NEMA 6-15R	N/A
208/230	16		NEMA 6-20R	2.5 - 3.6
208/230	24		NEMA 6-30R	4.2 - 5.0
277	16		NEMA 7-20R	2.5 - 5.0

